

HYLITE™
LED Lighting

LED
Lotus Lamp™

HyLite High Performance LED Lotus Lamps - Up to 60,000 hour* Rated Design Life. Outstanding Quality of Light with Energy Savings of 90% over Incandescent or Halogen Lamps and 67% over CFL Lamps.

500W
Incandescent or
PAR Halogen
Equivalent

High Performance LED Lotus Lamp, 60W

NEXGEN
PRODUCTS

Triac
Dimmable
Model

Designed for Easy Installation in New or Existing Fixtures, or as a Standalone Fixture, the HyLite LED Lotus Lamp is Suitable for a Wide Variety of Applications. Available in Multiple Beam Angles for Greater Light Control & Ideal Light Distribution. It Enhances Vision for Better Optical Acuity, reduces Light Pollution, and provides Clean, Crisp Light. The HyLite LED Lotus Lamp offers an Unprecedented Level of Light Output, Efficiency and Energy Savings that is Unmatched in the Industry today.

Suitable for Fully Enclosed Fixtures, its Compact Size makes it an Ideal Retrofit for Incandescent, Halogen, & HID Lamps. With Lamp Life of up to 60,000 hours, the HyLite LED Lotus Lamp Significantly Reduce Energy Consumption and Relamping Costs, consequently decreasing Maintenance and Disposal Costs.

- Versatile - the HyLite LED Lotus Lamp can be used with Direct Wire Connection for, Temporary or Portable Lighting. The Connectors are Water-proof.
- Extremely Efficient: High Lumen Efficacy: Up to 140 LpW
- Multiple Beam Angles for Greater Light Control: 25°, 40°, & 120° Solutions from Narrow Beam to Wide Floods.
- High >80+ CRI. Crisp Light for Greater Visibility and Safety.
- No Electro-Magnetic (EMi) or Radio Frequency Interference (RFI)
- Safe and Reliable: Isolated Circuit Design. Integral 2 kV Surge Suppressor and Protection. Includes a Free 20kA in-line SPD for added Protection.
- Cool Operation: Does not add to Heat Load while producing Brilliant Light
- Excellent Thermal Management with Proprietary-designed Heat Sink
- Easy Installation: No Ballast necessary. Use as a Fixture or as a Direct Retrofit into an existing Socket. Instant Start and Restart: No Warm-up Time required.
- Fully Encapsulated: Shatter-proof, High-Shock & High-Vibration Resistant
- Heat & Impact Resistant, UV Protected, Non-yellowing, Optical Grade Lens
- Ingress Protection: Complete protection against Contact, Dust Infiltration and Water Splashes
- Safe: Contain No Hazardous Materials; RoHS Compliant: No Lead, Mercury, Toxic Metals or Arsenic Gases. No Disposal Requirements. Facilitates LEED® points.
- Environmentally Friendly: 98% of the HyLite LED Lamp is Recyclable



US Patent
D860,481

FREE!
20 kA
In-line Surge Protection
Device Included.
Additional Protection
for your HyLite
Lotus Lamp
at no Cost!



Proprietary
& Patented
Design



Versatile and Adjustable - Use in Multiple Positions, Different Lengths and Various Angles for Directional Lighting



Incandescent or PAR Halogen	HID	CFL	HyLite LED
500W	250W	180W	60W
90%	76%	67%	Energy Savings (%)*

* Does not include Ballast Loss, Maintenance and Replacement Lamp Savings and Disposal Costs which can amount to additional Savings of 30~50%!

 Even & Uniform	 For Enclosed Luminaires	 Up to 60,000 Hours	 Reduction of up to 90%	 Vibration and Shock Resistant	 Zero Interference	 Radiation-Free No Humming	 Up to 140 LpW LM-79 Tested	 LM-80 Tested ISTMT Tested	 Safe and Reliable
--------------------	-----------------------------	------------------------	----------------------------	-----------------------------------	-----------------------	-------------------------------	--------------------------------	-------------------------------	-----------------------

*Depending upon the ambient temperature of the installation location

Model No.	Watts	Delivered Lumens	Maximum Install Height	Input Line Current	Dimensions & Weight (each)		
					Diameter	Height	Weight
HL-LS-60WD-EX-*-**	60	8,400	<26 ft. (8m)	217~418mA	7" (178mm)	7" (178mm)	2 lb. (920g)
HL-LS-60WD-GX-*-**							
HL-LS-60WD-WC-*-**							

Note: Triac Dimmable Model (for use with 120V Input Voltage Only)

Ordering Information: * -25 (for Narrow Flood Beam); -40 (for Flood Beam); -120 (for Wide Flood Beam)

** - 30K (for 3000°K); - 50K (for 5000°K)

Standard Beam Angle: 120°

Legend: EX = With EX-39 (Mogul) Base

GX = With GX16D Adapter

WC = With WC2 Adapter

- Minimum Lamp Compartment Dimensions for Enclosed Fixtures: 8" x 8" x 11" (203mm x 203mm x 280mm)
- To Prevent early Lamp Failure, Lamp should only be installed in Operating Environments ranging from a Minimum of -40°F (-40°C) to a Maximum of +131°F (+55°C)

- Efficacy: Up to 140 LpW
- Protection: IP65
- Ambient Working Temperature: -40°F~+131°F (-40°C~+55°C)
- CRI: >80+
- Rated Life: 50~60,000 Hrs.*
- Standard Beam Angle: 120°
- Triac Dimmable (for use with 120VAC, 50/60 Hz. Only)
- 277VAC to 120VAC available with External Step-Down Transformer [only](#).
- Max. THD (%): <20%
- Power Factor: >0.9
- Warranty: 5 Years

Please see HL-DT-70VA-277V-120V Spec. Sheet at: <https://hyliteledlighting.com/resources/specification-sheets/>

- 3000°K and 5000°K Standard CCT. Products with 2400°-6500°K (CCT) are available as "Special Orders" only and with Longer Lead Times

* Depending upon the ambient temperature of the installation location

Dimensions: (Shown with EX-39 (Mogul) Base)

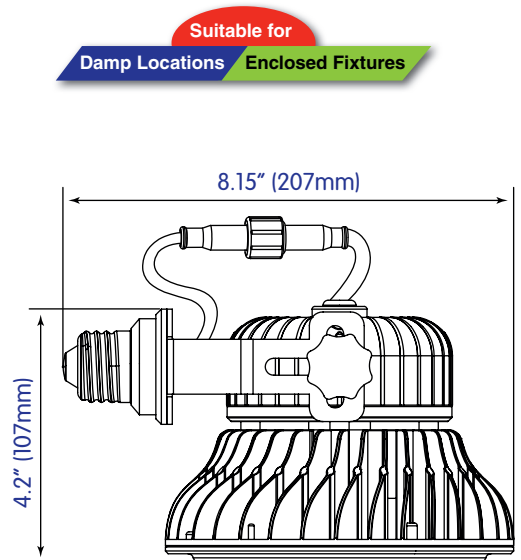
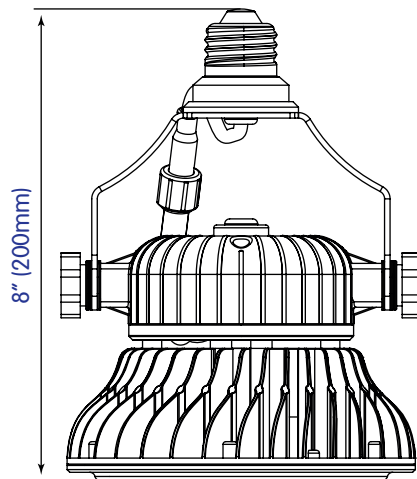
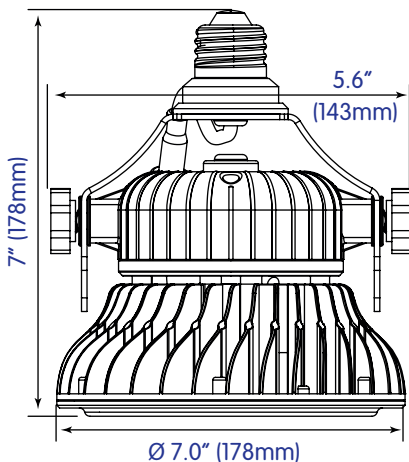

WARNING!
Minimum Lamp Compartment Size
8" x 8" x 11"
(203mm x 203mm x 280mm)

U.S. Patents: US D860,481 S and US D860,481 S-1

HyLite is providing this information to the general public only. Please note that all products contained herein are either Trademarked, Copyrighted, and/or have Patents or Patents Pending. Any use of these Designs is Strictly Prohibited. HyLite LED, LLC. Protects its Proprietary Information Vigorously in the Courts of the United States of America.

Installation: HyLite LED Triac Dimmable Lamps are Suitable for Use with 120V AC Input Voltage Only. Ballast (if equipped) must be Bypassed or Removed from the Fixture before installing the Lamp. Eliminating the Ballast saves Additional Costs related to Maintenance, Energy Consumption and Performance. By-passing Ballast will also ensure that there is no EMI/RF interference.

Warning: Failure to follow these Instructions will result in a Damaged Product and will VOID Warranty. It could also result in an Electric Shock, or Fire.



NO
LEAD, MERCURY,
HEAVY METALS
OR TOXIC GASES



98%
RECYCLABLE

Ideal for High-Quality illumination in:

- High Ceilings
- Studio Lighting
- Track Lighting
- Stage Lighting
- Spot Lighting
- Down Lights
- Accent Lighting
- Flood Lighting
- Low & High Bay Lighting
- Canopy Lights
- Decorative Lighting
- Site Lighting
- Pendant Lights
- Freezer & Cold Storage Lights
- Barn Lights



Multiple Beam Angles for Ideal Light Distribution

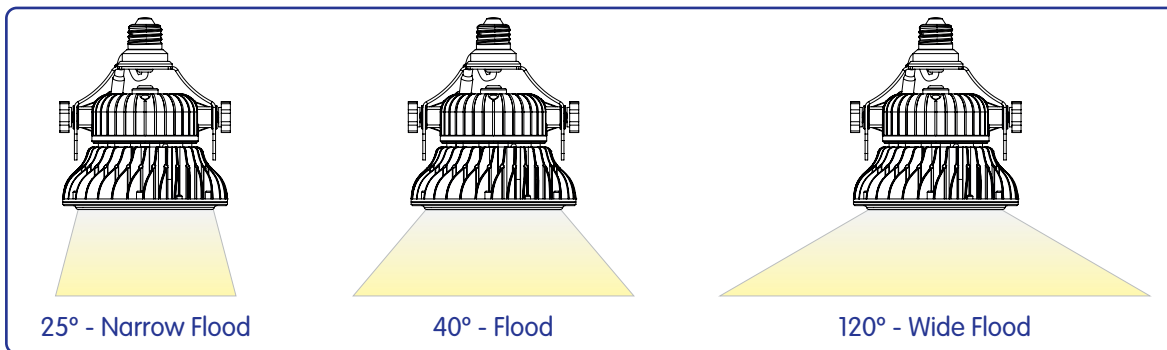

60W LED Lotus Lamp - Beam Angle, Average Illumination Charts

25°

40°

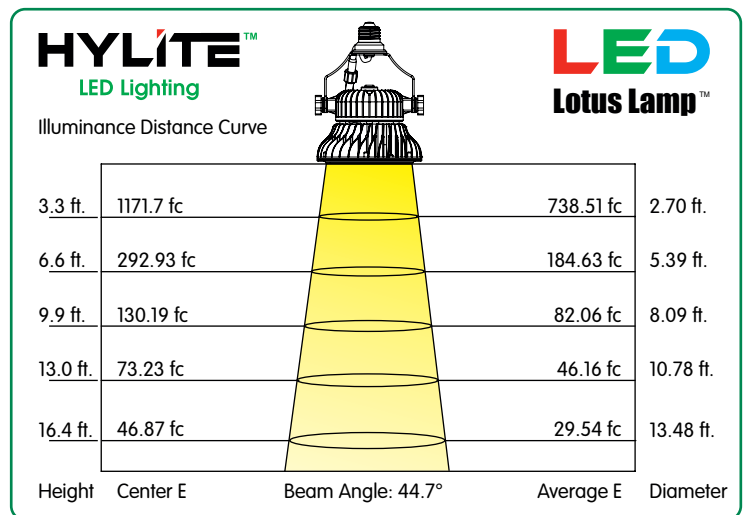
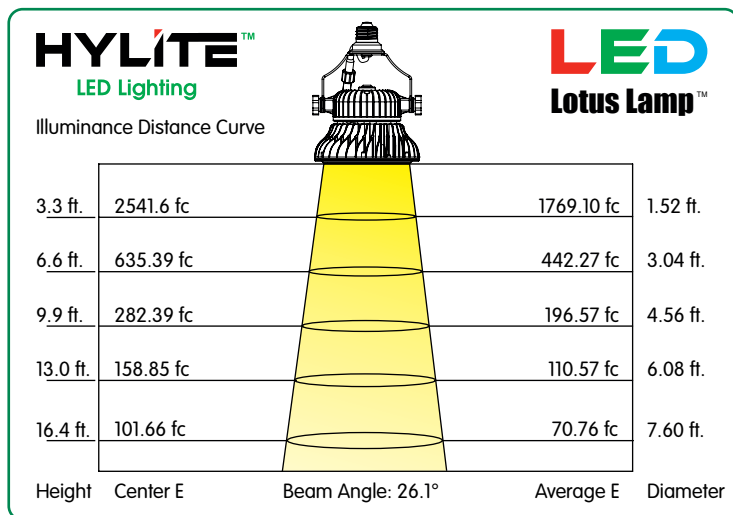

Note: The Curves indicate the illuminated area and the average illumination when the luminaire is at different distance

Quick Adapters:



HL-QA-GX16D-LS
GX16D Quick Adapter



HL-LS-WC2
2 Ft. (60cm)
Whip Connector
Quick Adapter



Lotus Lamp shown with GX16D Quick Adapter



Lotus Lamp shown with WC2 Quick Adapter

Warning - Risk of Fire or Electric Shock

- Disable all Power to the Lamp before Inspection, Installation, or Removal. Failure to do so will create a Hazardous and Fatal Working Environment.
- Suitable for use in Dry, Damp and Wet Locations. Lamp must be installed in accordance with National, State, and/or Local Electrical Codes. Do Not Open – No User Serviceable Parts Inside.
- Operate in Fixtures that provide the Free Flow of Air around the Lamp. In Enclosed Fixtures, ensure the Lamp has enough Space for Heat Dissipation. This will ensure Lumen Maintenance and Extend its Working Life. Failure to Follow these Instructions will result in a Damaged Product and will VOID Warranty. When Products are used in Outdoor Fixtures, ensure the Space is Waterproof and Well-Ventilated.
- DO NOT Block Light emanating from Product in Whole or Part, as this may Cause an Unsafe Condition.
- Not intended for use in Emergency Exit Fixtures or Exit Lights.
- Caution: When Installing Lamps in Corrosive Environments, HyLite suggests that a High-Temperature, Moisture-Resistant, Silicone Grease or Sealant be used to protect the Metal-threaded base of the LED Lamp to prevent Water and/or Moisture Incursion that can lead to Premature Degradation of the Lamp Base and eventual Lamp failure. This is especially recommended for LED Lamp Installations near Saltwater Bodies.
- Installing Surge/Lightning Protectors is Highly Recommended and helps to Eliminate Premature Driver Failure caused by Surges and Power Fluctuations.